

SMART Board RX series with iQ

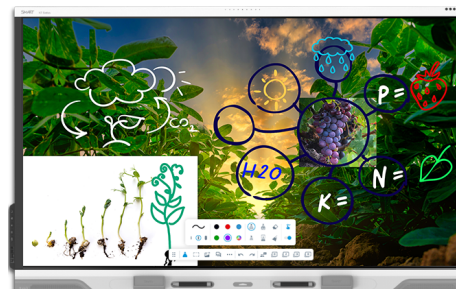

Display	
Screen sizes (diagonal)	65", 75", 86"
Backlight	LED
Aspect ratio	16:9
Maximum display resolution	4K UHD (3840 × 2160)
Refresh rate	60 Hz
Lifespan	≥ 50,000 hours
Brightness (maximum) ¹	490 cd/m ²
Response time	≤ 8 ms
Viewing angle	178°
Glass	Optically bonded anti-glare and anti-fingerprint heat tempered glass
Frame color	White
Convenience buttons	Home, power, volume, microphone mute, freeze frame
Sensors	Proximity, ambient light, infrared, room temperature, humidity, equivalent carbon dioxide (eCO ₂), volatile organic compound (VOC), Particulate Matter (PM _{2.5}) ²
Audio	Integrated soundbar featuring two 20 W speakers and a 15 W subwoofer Integrated linear eight-microphone array with visual mute status indicator and support for onboard acoustic echo cancellation

NFC

Integrated RFID NFC reader/writer CCID (chip card interface device) when used with a native driver for operating systems (Windows/Linux/Mac)

Supported protocols: ISO 14443A/B, ISO 15693, NFC Tag 1-4

Interactive experience	
Touch technology	HyPr Touch™ with Advanced IR
Touch features	Tool Explorer™ v2 Simultaneous Tool Differentiation Object Awareness™ Pen ID™ Silktouch™ Palm rejection
Typical response time	≤ 4 ms
Frame rate	≥ 300 Hz
Accuracy	1 mm
Minimum object size	2 mm
Multitouch capabilities	40 – Windows® 32 – Android™ 20 – Mac 10 – Chrome OS™
Tools included	Stylus with multi-tool select and fine eraser (x2) Erasers with angle of orientation (x2)
Tool holders	Intelligent, magnetic, frame-mounted
Optional tools	Stamps (available in 2024)

¹Brightness of individual displays can vary.

²The display's environmental sensors are not life safety rated sensors: they provide general information only.

Software	
iQ built-in Android™ experience	Included
SMART Notebook®	Included
SMART Ink® and SMART Product Drivers	Included
SMART Remote Management	Included ³
Optional software	See smarttech.com/education

iQ built-in Android experience	
Operating system	Android version 13 (forward compatible)
CPU	Octa-core
Memory	8 GB DDR4
OS architecture	64-bit
Storage	64 GB (up to 576 GB)
User interface	4K UHD (3840 × 2160)
Digital whiteboard	✓
Web browser	✓
Screen sharing	✓
Google Play Protect Certified⁴	✓
Google Play Store	✓
Other features	Personalized home screen and settings Split screen Picture-in-picture (PIP) Interactive widgets Templates, graphic organizers, and manipulatives File and app libraries Environmental sensors dashboard Tool Explorer Image Editor
Ability to run third-party applications	✓
Cloud storage access	✓
NFC sign in to a SMART Account	✓
Device based sign in to a SMART Account	✓
Languages supported	Basque, Catalan/Valencian, Chinese (simplified),

Chinese (traditional), Czech, Danish, Dutch, English, Estonian, Finnish, French, Galician, German, Greek, Hungarian, Italian, Japanese, Korean, Latvian, Lithuanian, Norwegian, Polish, Portuguese, Romanian, Russian, Slovak, Slovenian, Spanish, Swedish, Ukrainian, Vietnamese, Welsh

Updates	Automatic over-the-air (OTA)
----------------	------------------------------

PC computing	
OPS support⁵	SMART PCM modules
PC module power supported OPS	100 W
Optional computing modules	See smarttech.com/accessories

Inputs	Front	Back
OPS PC accessory slot (100 W devices)	–	1
MicroSD slot with security cover	–	1
HDMI® 2.1 4K @ 60Hz with HDCP 1.4, HDCP 2.3 and ARC support ⁶	1	3
VGA video	–	1
RS-232 (DB-9 connector)	–	1
RJ45 (LAN IN)	–	1
USB Type-C 4K @ 60Hz Display Port 1.2, USB 2.0 (UFP) for touch and digital audio, USB 3.2 Gen 1 (DFP) for peripherals; 65 W power delivery	1	1
USB Type-C, SuperSpeed (5 Gbps); 15 W power delivery	–	1 (top)
USB 2.0 Type-A	–	1
USB 3.2 Gen 1 Type-A	2	2
USB 3.2 Gen 1 Type-B	1	3

Outputs	Front	Back
HDMI 2.1 8K @ 60Hz with HDCP 2.3 support	–	1
USB Type-C 8K @ 30Hz Display Port 1.4a, HDCP 2.3 and HDCP 1.3, USB 3.2 Gen 1; 4.5 W power delivery	–	1
Stereo 3.5 mm (variable)	–	1
S/PDIF optical (fixed)	–	1
RJ45 (LAN OUT)	–	1

³Subscription for length of the included warranty.

⁴Pending final testing.

⁵The support and performance of third-party OPS (Open Pluggable Specification) and OPS-C modules may vary. Conduct proper compatibility testing to avoid potential issues.

⁶ARC support is available only with the HDMI 2 input.

Included cables and accessories	Qty
Country-specific power cable	1
16' 5"(5 m) USB 2.0 A to B cable	1
6' (1.8 m) USB Type-C 3.2 Gen 1, 5A	1
Stylus with multi-color select and fine eraser	2
Bar erasers	2
External tri-band Wi-Fi (2.4, 5, and 6-7.2 GHz) and Bluetooth (2.4 GHz) antennas	2
Remote control	1
AAA batteries	2
SMART ID cards (for NFC sign in to a SMART account)	2
Illustrated installation instructions	1
Important information document	1

Connectivity

Wired	RJ45 (x2) 1000baseT
Wi-Fi	IEEE 802.11ax (Wi-Fi 6E) supporting WPA, WPA2, PSK, WPA3, and 802.1X EAP authentication protocols
Bluetooth	5.2 dual mode

Storage and operating requirements

Power requirements	100V to 240V AC, 50 Hz to 60 Hz
Operating temperature	41–95°F (5–35°C)
Storage temperature	–4–140°F (–20–60°C)
Humidity	5–80% relative humidity, non-condensing

Power consumption

Typical	65": 94 W 75": 105 W 86": 122
Standby	<0.4 W

Certification and compliance*

Regulatory models	IDQR65-A, IDQR75-A, and IDQR86-A
US / Canada	FCC, ISED, TSCA, CONEG Packaging, Proposition 65
EU / EEA / EFTA / UK	CE, UKCA, LVD, CB, EMC, RED, REACH, RoHS, Battery, WEEE, Packaging, POP, Ecodesign
Australia / New Zealand	RCM
Performance standards	ENERGY STAR®, HDMI

Purchasing information

Order numbers

RX265	SMART Board® RX065 interactive display with iQ
RX275	SMART Board RX075 interactive display with iQ
RX286	SMART Board RX086 interactive display with iQ

Optional accessories

Order number: SWC-120UHD	SMART Ultra HD Camera 120
	See smarttech.com/accessories

Warranty

Includes advanced hardware replacement and access to onsite support. Terms and conditions vary by region. Contact your local reseller or distributor for information and visit smarttech.com/warranty.

*Product availability may vary by region.

This product has received additional certifications not listed here.

Cable requirements

HDMI	Certified premium high speed HDMI (18 Gbps) Maximum length: 23' (7 m)
USB 2.0	USB 2.0 certified Hi-Speed (480 Mbps) support Maximum length: 16' (5 m)
USB 3.0	USB 3.0 certified SuperSpeed (5 Gbps) support Maximum length: 9' (3 m)
USB Type-C	SuperSpeed (5 Gbps) support Maximum length: 6' (2 m)
More information	See smarttech.com/kb/171555

Installation, dimensions, and weights

Notes

- All dimensions $\pm 1/8"$ (0.3 cm). All weights ± 2 lb. (0.9 kg).
- Product ships upright.
- Leave space around the display to ensure adequate ventilation.

65" model

Dimensions

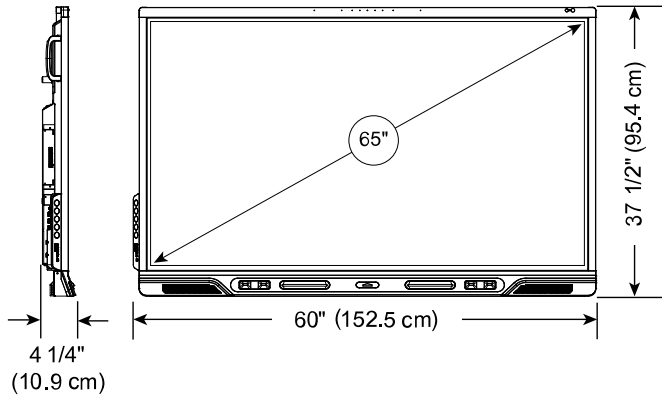

Weight

92.6 lb. (42 kg)

Shipping dimensions (including pallet)

65 1/2" \times 46" \times 7 1/8"
(166.5 cm \times 117 cm \times 18 cm)

Shipping weight

108 lb. (49 kg)

VESA mount

M8, 600 \times 400 mm

Handles

2

75" model

Dimensions

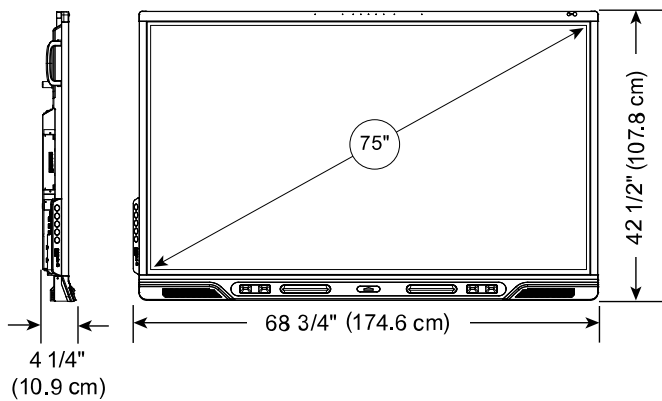

Weight

124 lb. (56 kg)

Shipping dimensions (including pallet)

74 5/8" \times 50 7/8" \times 7 1/8"
(189.5 cm \times 129.3 cm \times 18 cm)

Shipping weight

147 lb. (67 kg)

VESA mount

M8, 800 \times 400 mm

Handles

2

86" model

Dimensions

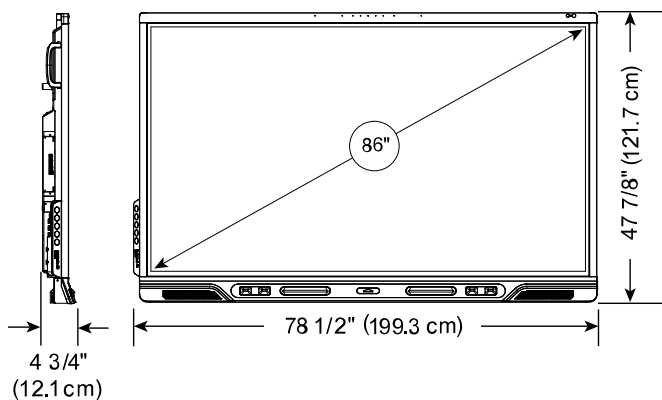

Weight

154 lb. (70 kg)

Shipping dimensions (including pallet)

84 1/4" \times 57 1/4" \times 7 5/8"
(214 cm \times 145.4 cm \times 19.5 cm)

Shipping weight

190 lb. (86 kg)

VESA mount

M8, 800 \times 600 mm

Handles

2

smarttech.com
smarttech.com/contact

© 2024 SMART Technologies ULC. All rights reserved. SMART Board, SMART Ink, HyPr Touch, Tool Explorer, SMART TeamWorks, SMART Meeting Pro, Object Awareness, Pen ID, Silktouch, smarttech, the SMART logo and all SMART taglines are trademarks or registered trademarks of SMART Technologies ULC in the U.S. and/or other countries. Android and Chrome OS are trademarks of Google Inc. The Bluetooth word mark is owned by the Bluetooth SIG, Inc. and any use of such marks by SMART Technologies ULC is under license. The Adopted Trademarks HDMI, HDMI High-Definition Multimedia Interface, and the HDMI Logo are trademarks or registered trademarks of HDMI Licensing Administrator, Inc. in the United States and other countries. All other third-party product and company names may be trademarks of their respective owners. This product and/or use thereof is covered by one or more of the following U.S. patents: www.smarttech.com/patents. Models and specifications may vary by region. Please contact your local representative for details. Contents are subject to change without notice. April 4, 2024.